

HUTCHINSON GRAIN PUMP™



MOVES A WORLD OF GRAIN

Hutchinson

THE WORLD OVER

HUTCHINSON GRAIN PUMP™ ... MOVE YOUR GRAIN UP, AROUND AND BACK TO LOAD OUT.



Installation of a Grain Pump™ loop system into a new two bin storage structure.

The innovative Hutchinson Grain Pump™ lets you move grain with gentle efficiency and at high capacities. It requires less horsepower than air systems and Hutchinson's en masse (grain-moving-grain) concept causes less damage to grain and needs less maintenance than traditional conveying systems.

The secret is Hutchinson's unique UHMW paddle, designed to keep your grain flowing gently and evenly from inlet to discharge.

These round, plastic paddles are spaced every 13", taking the place of traditional auger flighting. These paddles are notched to go around corners. Grain Pump™ owners have found a reduction in grain damage when compared to traditional conveying systems.

The closed-loop design offers the versatility to create a complete load-in/load-out system that also provides recirculation capabilities. One or more bins can be unloaded at a time into the loop. Reduced drying costs can be achieved with this innovative system by blending higher moisture and dried grain from one bin to another. Possibilities are nearly unlimited. Install the Grain Pump™ underneath a row of bins (see illustration), or in an existing in-line system, the pump may be angled to pick-up from conventional unload in front. The loop system may provide down-the-road expansion capabilities.

Let Hutchinson tailor a Grain Pump™ to your storage system.



SPECIFICATIONS

Dimensions of Conveying Chamber	6"	8"	10"
Maximum Capacity in BPH	2,000	4,000	6,000
Chain Travel in FPM	325	362	364
Housing Gauge, Galv.	12	12	12
Paddle Thickness (UHMW)	3/8"	3/8"	1/2"
Corner Shaft Diameter	1 1/2"	2"	3"
Conveyor Chain	81X	81X	81X
Conveyor Horsepower Required*			
Per Foot Vertical	.20	.35	.50
Per Foot Horizontal	.05	.08	.11
Weight per foot of Tubular Conveyor			
Empty	10 lbs.	12 lbs.	15 lbs.
Full of 45 lbs. per cu. ft. material	19 lbs.	28 lbs.	40 lbs.

* Clean dry non-abrasive grain

Shown with Support Tower
(not supplied by Hutchinson)

CALL TOLL-FREE
1-800-523-6993
for the nearest dealer or distributor.

MOVES A WORLD OF GRAIN

Hutchinson

THE WORLD OVER

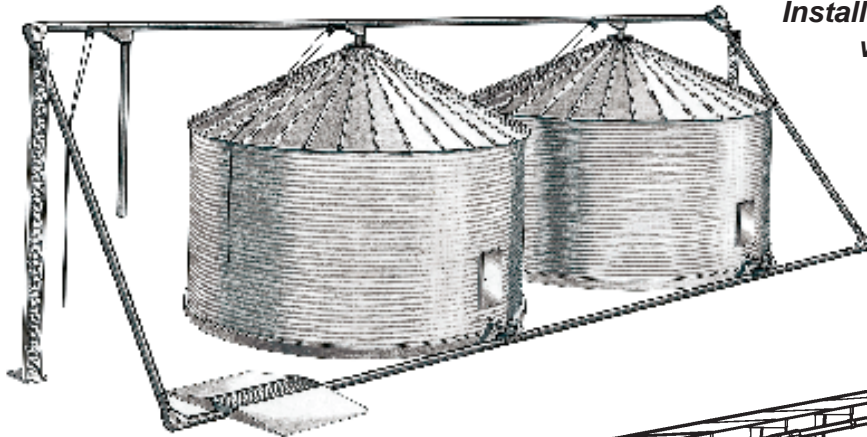

Installations of loop systems with existing bins.

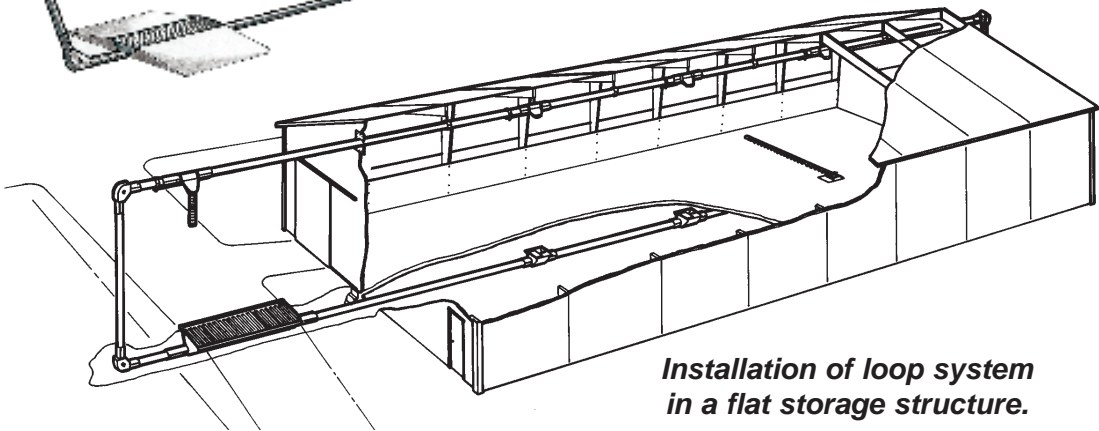

Installation of loop system in a flat storage structure.



The Hutchinson Grain Pump™ is designed for new or existing storage installations.

CALL TOLL-FREE
1-800-523-6993

HUTCHINSON

P.O. Box 629 • Clay Center, Kansas 67432 • Ph. (785) 632-2161 • FAX (785) 632-5964 • <http://www.hutchweb.com>